



3 GHz N N/O S.P.6 T. SWITCH

OPTIONS : / TTL DRIVE /SUPP.DIODES

R F CHARACTERISTICS

NUMBER OF WAYS : 6
 FREQUENCY RANGE : 0 - 3 GHz
 IMPEDANCE : 50 Ohms

| | |
|-----------------|---------|
| FREQUENCY (GHz) | 0 - 3 |
| V.S.W.R <= | 1.20 |
| INSERT. LOSS <= | 0.20 dB |
| ISOLATION >= | 80 dB |
| AVER. POWER (*) | 300 W |

ELECTRICAL CHARACTERISTICS

ACTUATOR : NORMALLY OPEN
 NOMINAL CURRENT AT 25° C (±10%) : 250 mA
 ACTUATOR VOLTAGE (Vcc) : 12V (10.2 to 13V) / NEGATIVE COMMON
 TERMINALS : solder pins (250°C max./30 sec.)
 TTL INPUTS (E) - High level : 2.2 to 5.5V / 800µA at 5V
 - Low level : 0 to 0.8V / 20µA at 0.8V

MECHANICAL CHARACTERISTICS

CONNECTORS : N female per MIL C 39012
 LIFE : 2.000.000 cycles per position
 SWITCHING TIME (nominal voltage;25° C) : < 15 ms
 CONSTRUCTION : splashproof
 WEIGHT : < 460 g

ENVIRONMENTAL CHARACTERISTICS

OPERATING TEMPERATURE RANGE (°C) : -40 , +85
 STORAGE TEMPERATURE RANGE (°C) : -55 , +85

(* : average power at 25° C per RF path)

4112-9212 This information is given as an indication. In the continual goal to improve our products, we reserve the right to make any modifications judged necessary

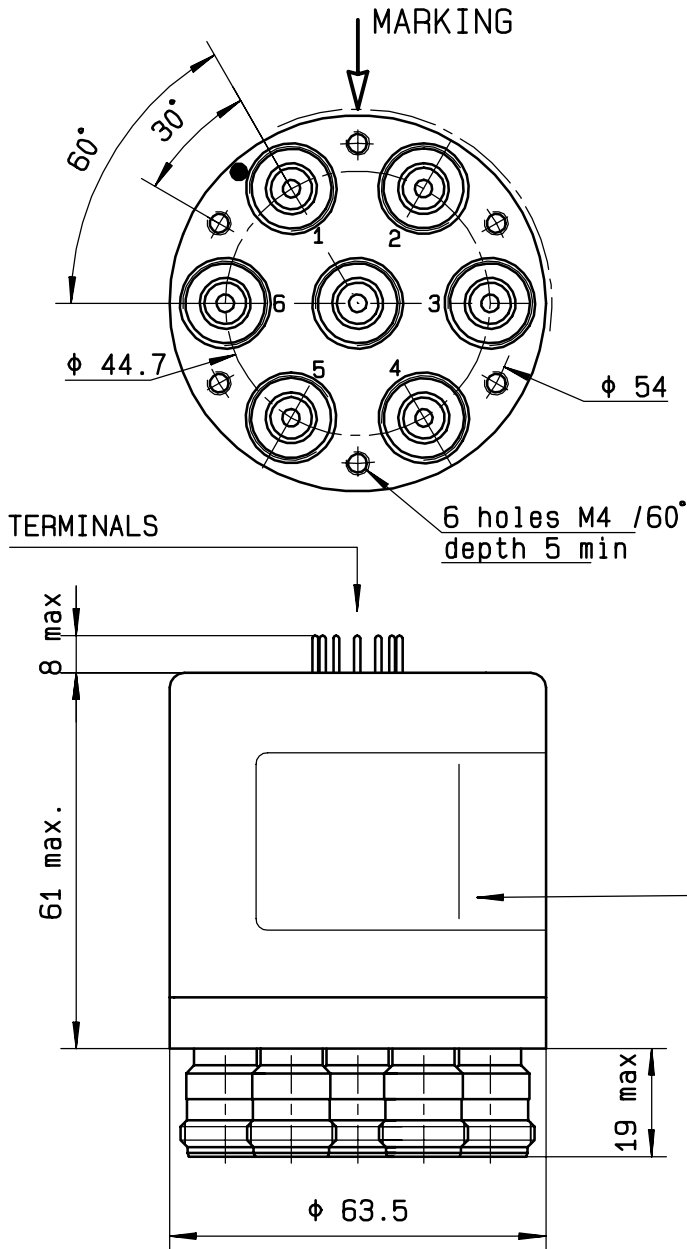

| TTL input | RF continuity |
|-----------|---------------|
| E1 = 1 | IN ↔ 1 |
| E2 = 1 | IN ↔ 2 |
| E3 = 1 | IN ↔ 3 |
| E4 = 1 | IN ↔ 4 |
| E5 = 1 | IN ↔ 5 |
| E6 = 1 | IN ↔ 6 |

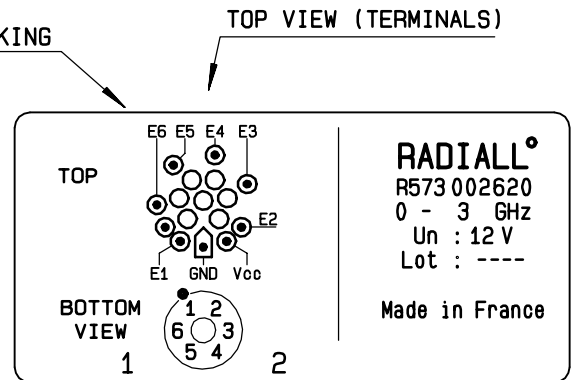

RADIALL[®]
 R573 002620
 0 - 3 GHz
 Un : 12 V
 Lot : ----
 Made in France

SCHEMATIC DIAGRAM

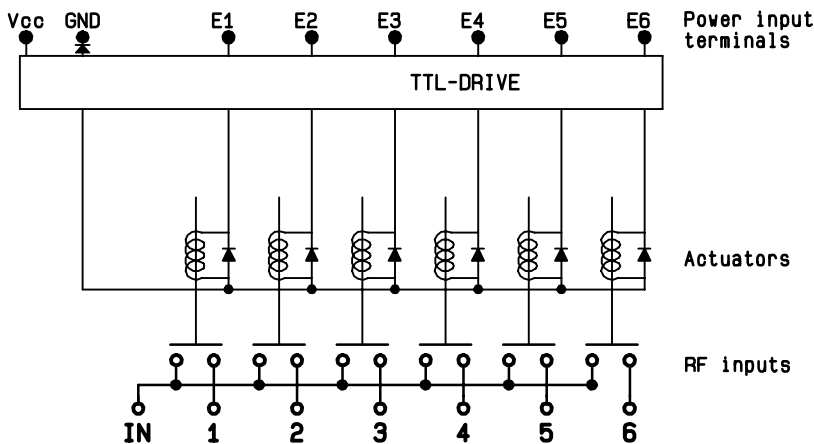

4113-9212 This information is given as an indication. In the continual goal to improve our products, we reserve the right to make any modifications judged necessary